

Bent axis hydraulic motors

MXP

Series



 **HYDRO
LEDUC**
TOHIO[®]

Contents

■ Definition and main applications of hydraulic motors, advantages of LEDUC motors	1
■ Operating conditions of motors	2
■ Determining the right motor	3
■ Range and characteristics	4
■ Efficiency curves	5
■ Dimensions	6
■ ATEX certification	7
■ Installation and start-up recommendations	8
■ Other LEDUC product lines	9

MXP series motors

LEDUC hydraulic motors of the MXP series are of bent axis design, with an angle of 40°. They combine high performance and reduced size envelope:

- global efficiency of over 90% (guaranteed in most applications);
- suitable for use at operating speeds between 50 and 8,800 rpm;
- optimized weight and size.

Available in displacements from 12cc to 126cc, MXP motors are designed for applications on trucks or construction type equipment, where intensive use is intermittent. (For heavy duty applications, HYDRO LEDUC offers M and MSI series motors, literature available on request.)

MXP motors are designed for use in either closed or open loop systems.

To ensure the best service life from your motors, please take care to follow the installation and start-up recommendations (see pages 2 and 8).

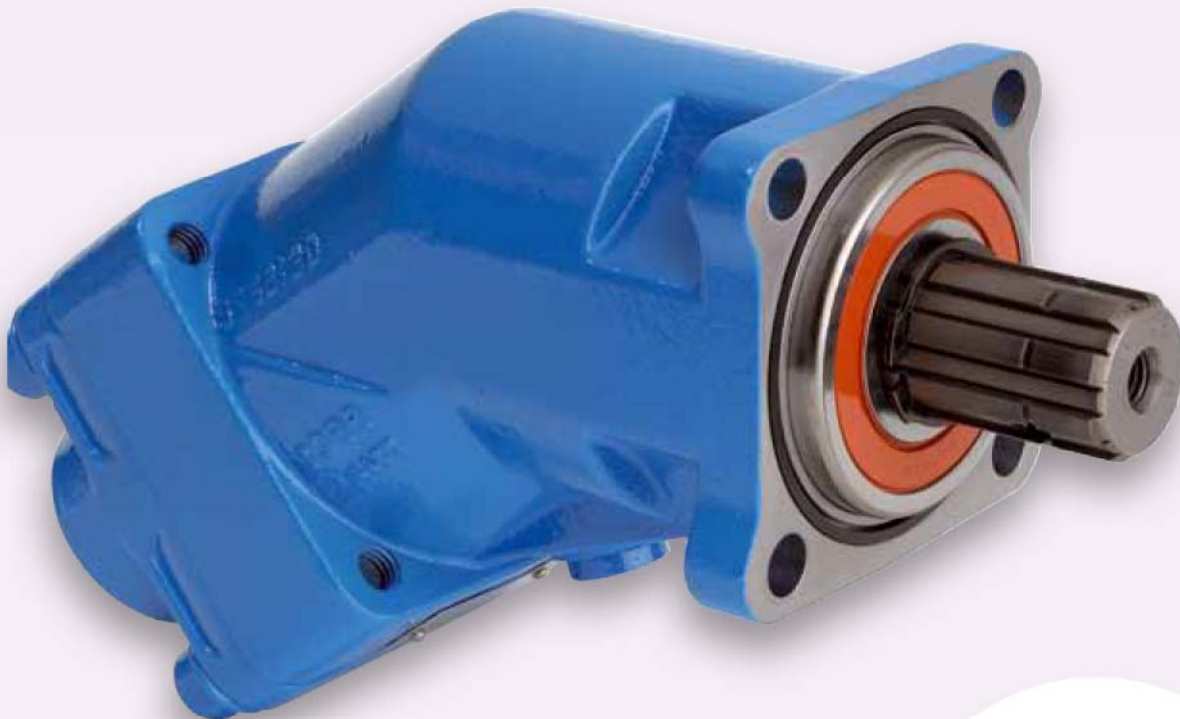

 **HYDRO
LEDUC**

HYDRO LEDUC also manufactures a range of semi-integrated (plug-in) motors, the **MSI** series and range of ISO flange motors: the **M** series type **M**. Literature on request or on our website : www.hydroleduc.com

HYDRO LEDUC

Head Office & Factory
BP 9
F-54122 AZERAILLES (FRANCE)
Tél. +33 (0)3 83 76 77 40
Fax +33 (0)3 83 75 21 58

Advantages of MXP series motors

■ Definition of function

Hydraulic motors transform hydraulic flow into rotating speed and hydraulic pressure into mechanical torque.

Motor rotating speed is proportional to the flow which is supplied to it.

Torque produced is proportional to the hydraulic pressure the motor receives.

■ Main applications of hydraulic motors

Typical applications are those requiring high torque within a small size.

The hydraulic motor is essential for rotations where:

- mechanical solutions are complex or even impossible,
- electrical or pneumatic power sources are not available,
- environments are dangerous (i.e. risk of explosion or extreme temperatures).

■ Advantages of LEDUC motors

All structural components are made from similar materials resulting in consistent thermal expansion and exceptional reliability.

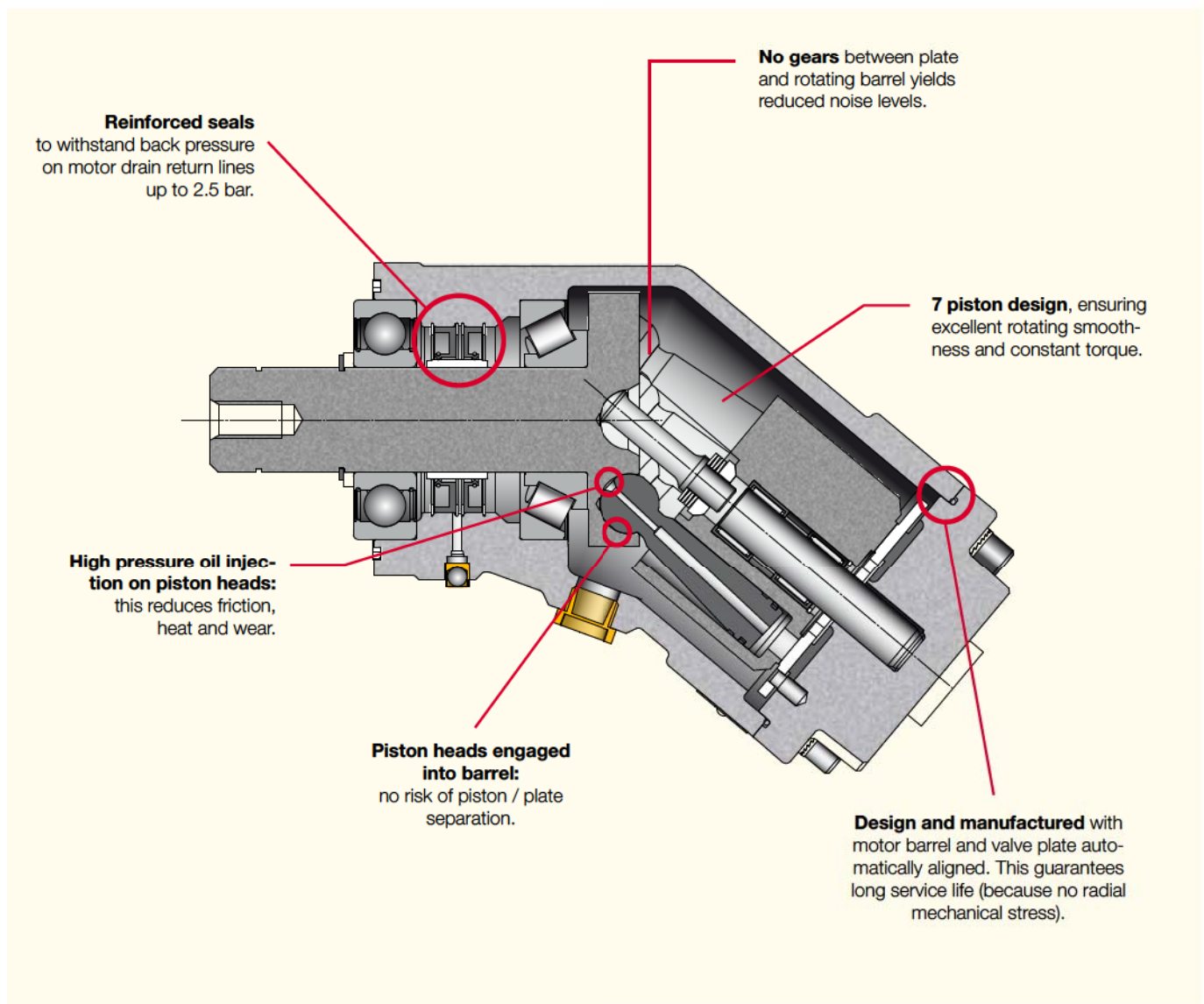

Operating conditions of MXP series motors

Hydraulic fluid

LEDUC motors are designed to be powered with mineral based hydraulic fluid. Using other fluids is possible but may require a modified motor. Please contact us with details of fluid.

Recommended viscosity:

- Ideally : between 15 and 200 cSt;
- Maximum range: between 5 and 1600 cSt.

Filtration of hydraulic fluid

The service life of the motors depends greatly on the quality and the cleanliness of the hydraulic fluid.

We recommend minimum cleanliness as follows:

- NAS 1638 class 9
- SAE class 6
- ISO/DIS 4406 class 18/15.

Direction of rotation

The motors rotate clockwise or counter-clockwise depending on the direction of hydraulic flow entering the motor.

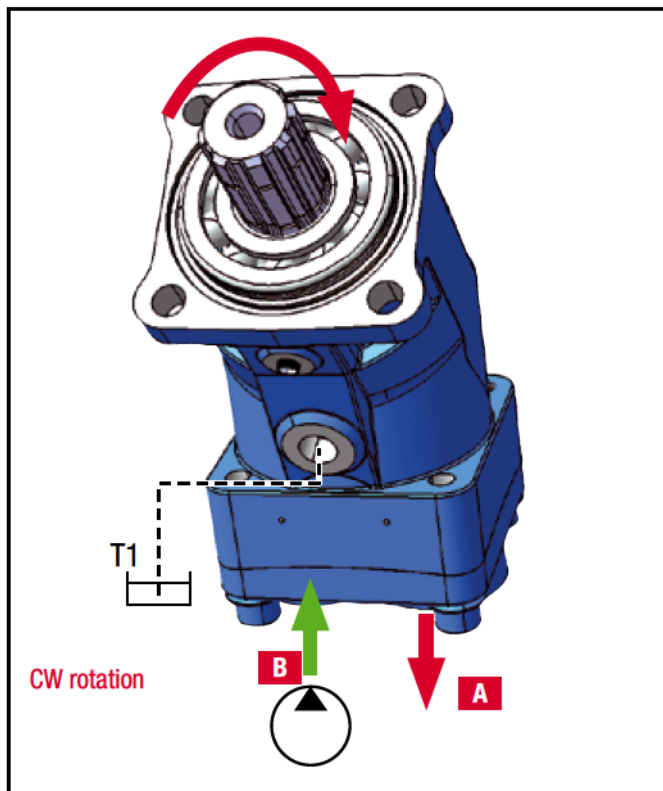

Rotating speeds

Minimum rotating speed to obtain continuous rotation is 200 rpm (however, in certain conditions, the motor can run at speeds as low as 50 rpm).

Maximum rotating speed is given for each model of motor (see page 4).

Installation positions

LEDUC motors are made to operate in all positions.

Important note : before start up, ensure the motor is filled with hydraulic fluid. (See section on installation and start-up, page 8).

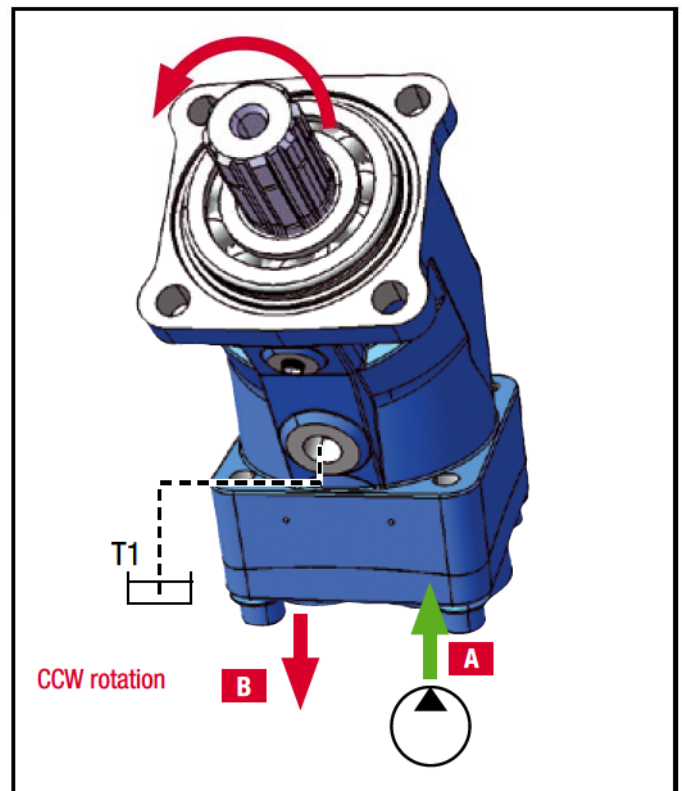

Drain pressure

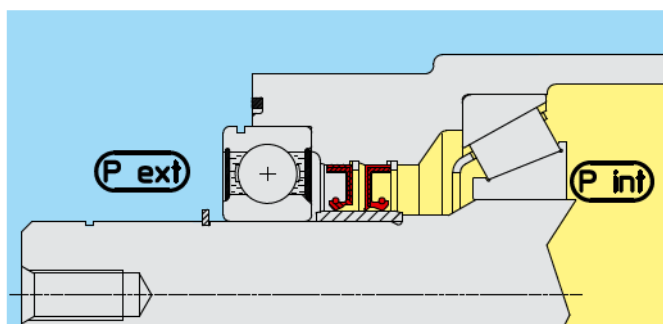

It is essential to drain the motor (T1) to avoid excessive pressures on the shaft seal.

Maximum acceptable internal pressure depends on motor rotating speed.

However, following these guidelines will avoid problems during operation:

- maximum internal pressure (P_{int}) regardless of rotating speed (continuous): 2.5 bar (60psi);
- maximum internal pressure (P_{int}) regardless of rotating speed (peak): 3 bar (80psi);
- minimum pressure in the motor housing: must be greater than ambient (external) pressure (P_{ext}).

Determination MXP series motors

How to determine the correct motor for your application

Calculations using usual mechanical units:

- N = rotating speed in rpm
- C = torque in N.m
- P = pressure supplied by the generator (hydraulic pump), in bar
- ΔP = pressure difference between A and B, in bar
- Disp. = displacement in cc
- Q = flow in litres per minute
- η = efficiency (%)

1. Torque supplied by the hydraulic motore

$$\text{Theoretical torque} = \frac{\text{Disp.} \times \Delta P}{20 \pi} = C_m$$

$$\text{Torque } C = C_m \times \eta_{\text{motor}}$$

For example: a 50cc motor with a ΔP of 250 bar will supply a theoretical torque of : 200 N.m.
Average global efficiency of the motor is 90%, actual torque is thus: 180 N.m

2. Rotating speed of the motor

The rotating speed of the hydraulic motor depends on the flow Q which goes through it, and on the displacement of the motor.

$$N = \frac{Q}{\text{Disp.}} \times 1000$$



test bench for motors

Example

- ① Motor
- ② Variable displacement pump
- ③ Pressure relief valve
- ④ Valve
- ⑤ Hydraulic motor
- ⑥ Winch and load

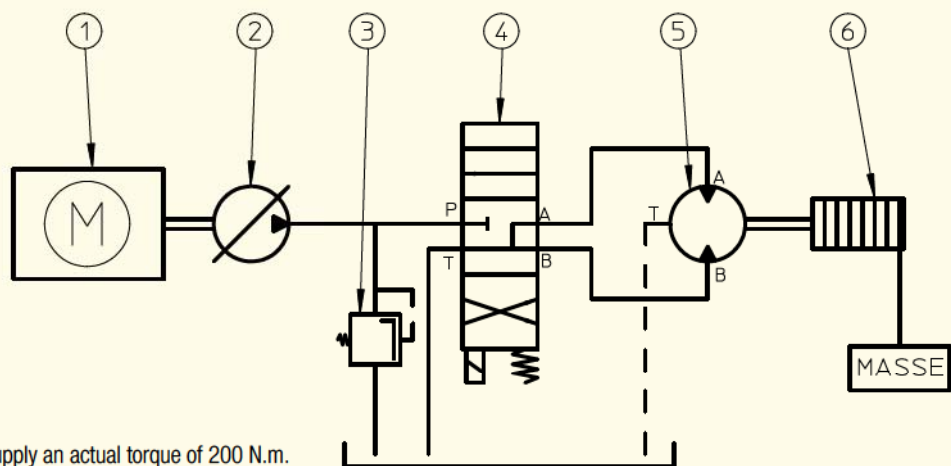

The receiving organ (winch) ⑥ needs to rotate at $N = 400$ rpm and supply an actual torque of 200 N.m.

The hydraulic pump ① is capable of operating at pressure P up to 350 bar.

1. Calculating the displacement of the hydraulic motor:

$$C_m = \frac{\text{Disp.} \times \Delta P}{20 \pi} \text{ thus Disp. } \mathbf{Cy = 35.9 \text{ cc}}$$

▶ In the LEDUC range, choose a motor with a displacement of **32 cc** or **41 cc**.

2. Calculating the flow Q which the pump needs to supply:

$$N = \frac{Q}{\text{Disp.}} \times 1000 \text{ thus } \mathbf{Q = 14.36 \text{ l/min}}$$

Corresponding flow :
- for **32 cc** motor, $Q = 12.8 \text{ l/min}$
- for **41 cc** motor, $Q = 16.4 \text{ l/min}$

Range and characteristics MXP series motors



■ Characteristics of the MXP series motors

MXP series motors are designed for use on:

- truck equipment;
- construction equipment;
- agricultural machinery;

for intermittent service applications.

These motors are designed with a DIN interface.

Motor model	Displacement (cc)	continuous max. speed ⁽¹⁾ (rpm)	Intermittent max. speed ⁽¹⁾ (rpm)	Max. flow absorbed (l/mn)	Torque bar (m.N/bar)	Torque at 350 bar (m.N)	Motor max./min. temperature* (°C)	Max. allowable pressure continuous / peak (bar)
MXP12-092965	12	8000	8800	96	0.19	66	-25 / 110	400 / 450
MXP18-092890	18	8000	8800	144	0.28	98	-25 / 110	400 / 450
MXP25-092895	25	6300	6900	158	0.4	140	-25 / 110	400 / 450
MXP32-092900	32	6300	6900	202	0.5	175	-25 / 110	400 / 450
MXP41-092905	41	5600	6200	230	0.65	227	-25 / 110	400 / 450
MXP50-092910	50.3	5000	5500	252	0.8	280	-25 / 110	400 / 450
MXP63-092915	63	5000	5500	315	1	350	-25 / 110	400 / 450
MXP80-092925	80.4	4500	5000	362	1.27	445	-25 / 110	400 / 450
MXP108-092930	108.3	4000	4400	435	1.7	595	-25 / 110	400 / 450
MXP126-092970	126	3400	4400	428	2.0	700	-25 / 110	400 / 450

* for wider extreme temperatures, please contact us.

(1) for higher speeds, please contact us.

For special fluids, please contact us.

4

■ Acceptable forces applied to motor shaft

Fr : radial force measured at mid point of length of shaft.

Avoid having any radial or axial force on the shaft of MXP motors. If that is not possible, please contact our Technical Department with details of application.

Motor model	MXP 12	MXP 18	MXP 25	MXP 32	MXP 41	MXP 50	MXP 63	MXP 80	MXP 108	MXP 126
Fa (N/bar*)	15	20	30	30	40	40	50	60	80	90

* differential pressure between A and B.

For other forces, please contact us.

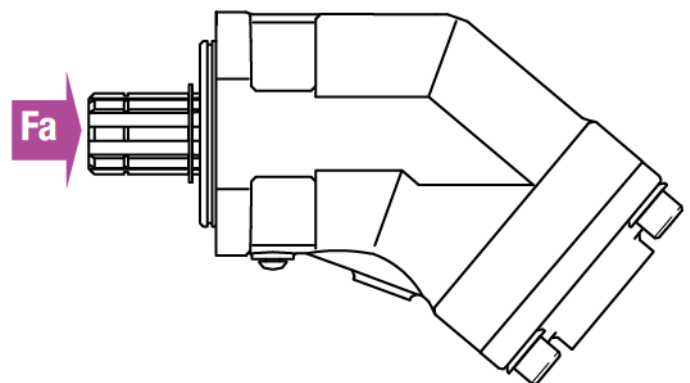

Efficiency MXP series motors

Efficiency of motors f(displacement)

N of motor = 1000 rpm
ISO46 fluid at 25°C

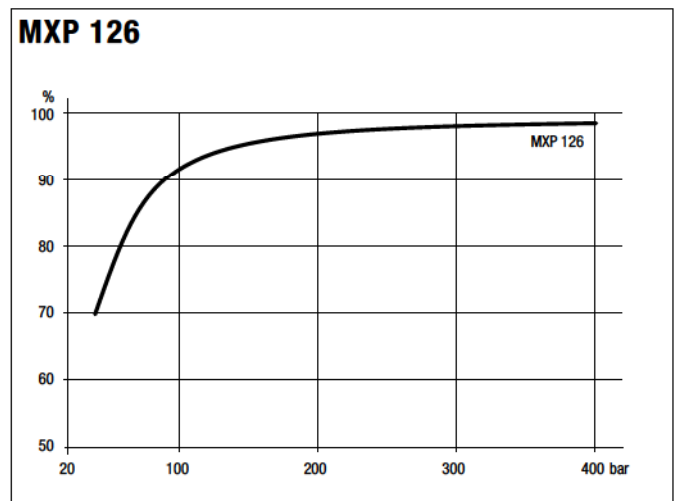
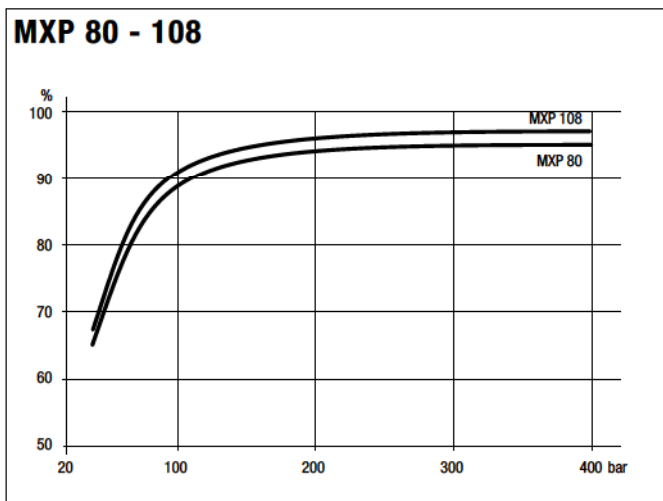
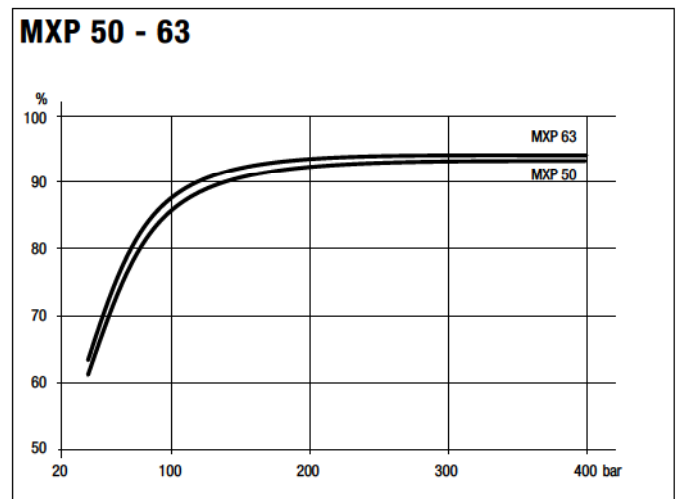
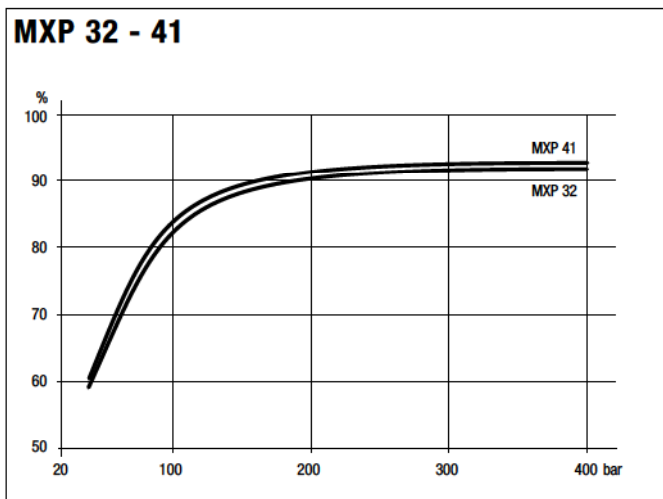
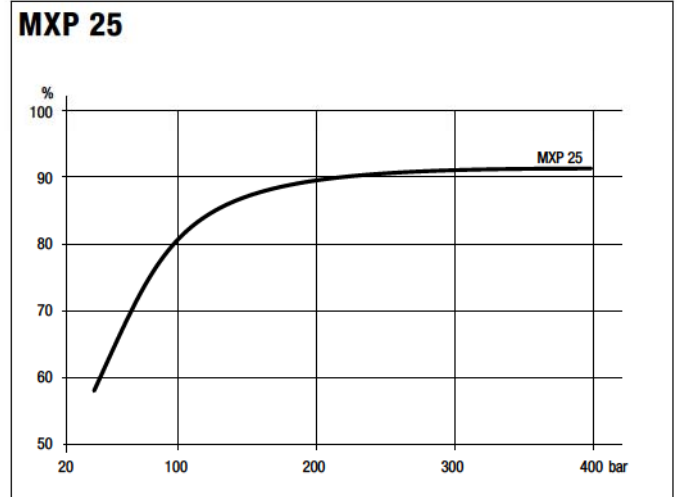
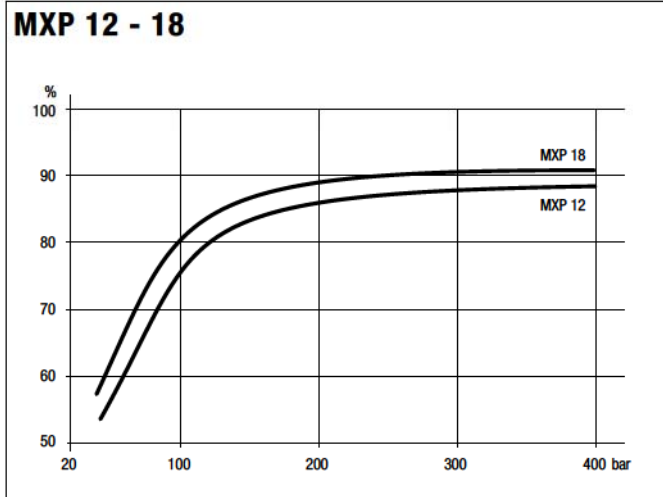

Dimensions MXP series motors

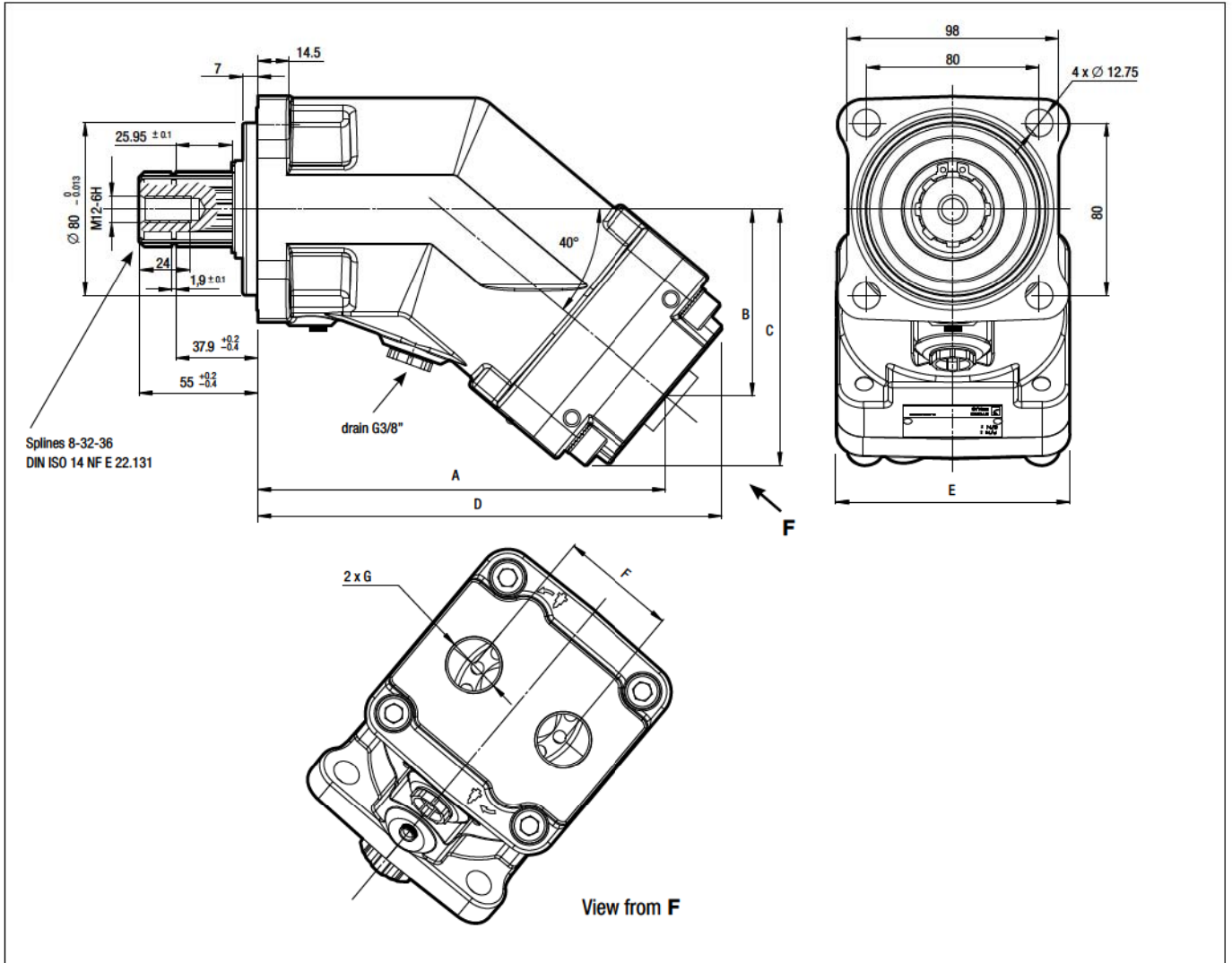

Motor model	Dis. (cc)	A	B	C	D	E	F	G	weight (kg)
MXP12-092965	12	171.5	71.9	103.9	197.9	108.5	54	G 3/4"	9.3
MXP18-092890	18	171.5	71.9	103.9	197.9	108.5	54	G 3/4"	9.3
MXP25-092895	25	171.5	71.9	103.9	197.7	108.5	54	G 3/4"	9.3
MXP32-092900	32	177.7	77	109.1	203.8	108.5	54	G 3/4"	10.3
MXP41-092905	41	177.7	77	109.1	203.8	108.5	54	G 3/4"	10.3
MXP50-092910	50,3	189.3	86.8	118.9	215.4	108.5	54	G 3/4"	11.5
MXP63-092915	63	189.3	86.8	118.9	215.4	108.5	54	G 3/4"	11.5
MXP80-092925	80,4	216.2	99.5	133.3	241.7	123.5	60	G 1"	14.5
MXP108-092930	108,3	216.2	99.5	133.3	241.7	123.5	60	G 1"	14.5
MXP126-092970	126	218.5	101.43	135.2	244	123.5	60	G 1"	14.5

■ LEDUC motors can be certified ATEX; please consult us.



1

2

3

4

- 1 Dimensional control of MXP motor housing
- 2 Assembly of MXP motor
- 3 Spline cutting (shaft)
- 4 MXP motors

Installation and start-up MXP series motors

■ Maximizing service life of bearings

In cases where there is a radial force on motor shaft, keeping the direction of that force within the shaded areas shown below will improve service life of the motor.

For acceptable radial and axial forces, see page 4.

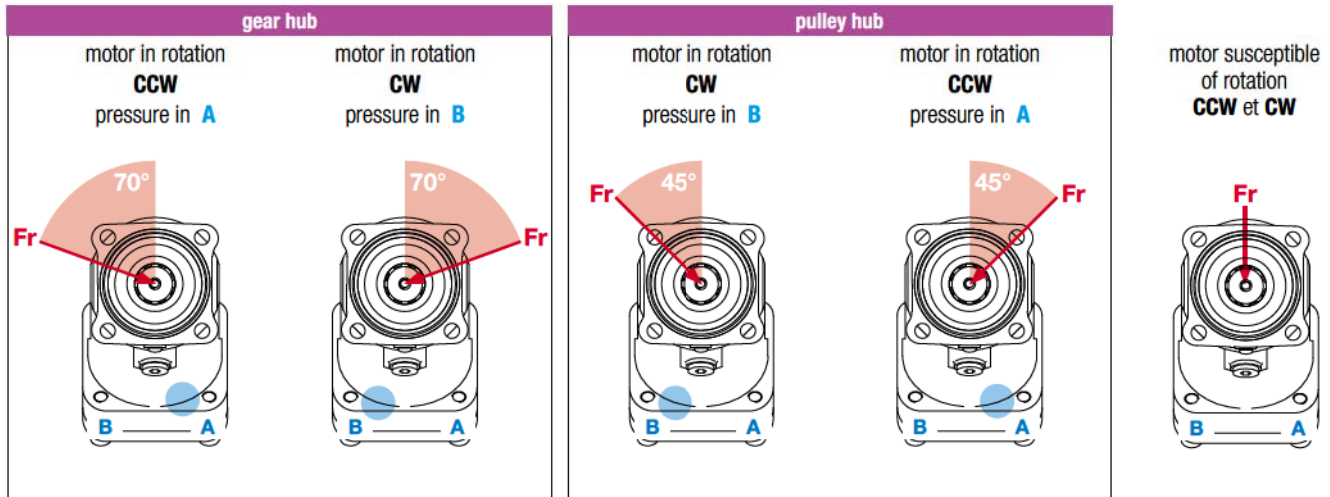

■ Mounting position of motors

LEDUC motors can be used in any position.

8

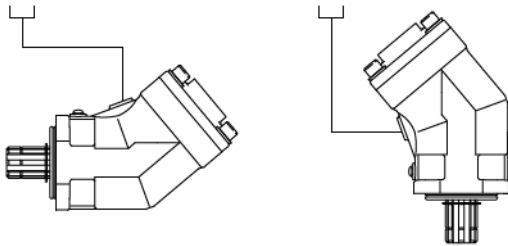

In installations where the position of the motor (H) is above the tank for the drain return, be sure the drain line is always submerged in fluid.

If this is not the case, it is necessary to add a check valve on the drain line following the figure below.

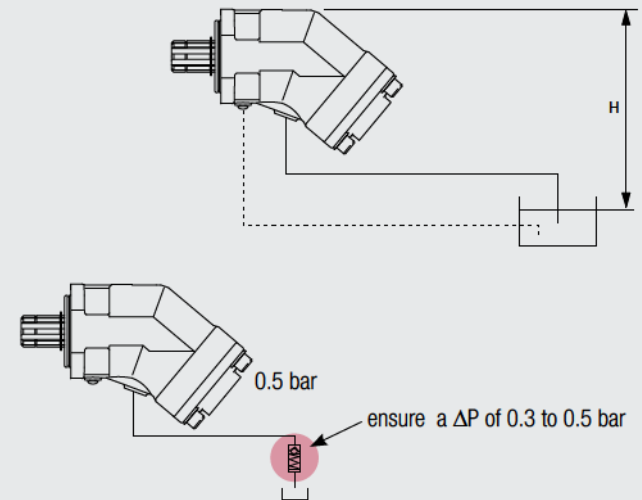

■ Operating conditions

See page 2.

■ Instructions for use

Each motor is supplied with an instruction leaflet, also available via e-mail on request mail@hydroeduc.com.

other product lines

hydraulic motors

Fixed displacement bent-axis pistons motors. Models from 12 to 126 cc. Available both in ISO and SAE versions.

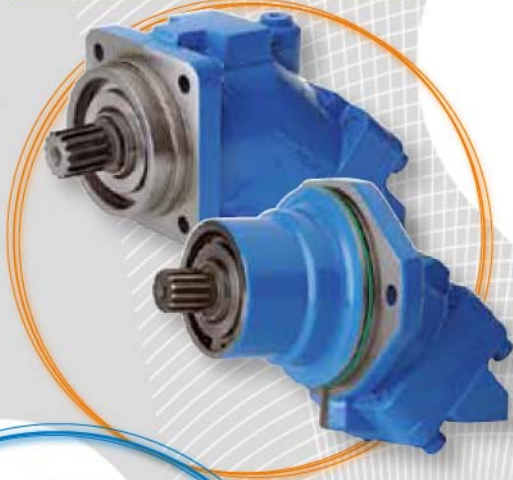

mobile and industrial pumps

Fixed displacement pumps, the W series, and variable displacement pumps, the DELTA series. High pressure capabilities within minimal size.

W series: flanges to ISO 3019/2, shafts to DIN 5480.
DELTA series: SAE shafts and flanges.



hydro-pneumatic accumulators

Bladder, diaphragm accumulators. Spherical and cylindrical accumulators. Volume capacities from 20 cc to 50 liters. Pressures up to 500 bar. Accessories for use with hydraulic accumulators.

TXV

XP

PA
PAC
PAD

piston pumps for trucks

HYDRO LEDUC offers 3 types of piston pumps perfectly suited to all truck and PTO-mount applications. Fixed and variable displacement from 12 to 150 cc.

micro-hydraulics

This is a field of exceptional HYDRO LEDUC know-how:

- axial and radial piston pumps, of fixed and variable displacement,
- axial piston micro-hydraulic motors,
- micro-hydraulic units incorporating pump, electric motors, valving, controls, etc.

To users of hydraulic components which have to be housed in extremely small spaces, HYDRO LEDUC offers complete, original and reliable solutions for even the most difficult environments.



we are passionate about hydraulics...

HYDRO LEDUC

A dedicated R&D team means HYDRO LEDUC is able to adapt or create products to meet specific customer requirements. Working in close cooperation with the decision-making teams of its customers, HYDRO LEDUC optimizes proposals based on the specifications submitted.

a passion for hydraulics

HYDRO LEDUC

Head Office & Factory
BP 9 - F-54122 AZERAILLES (FRANCE)
Tél. +33 (0)3 83 76 77 40
Fax +33 (0)3 83 75 21 58

HYDRO LEDUC GmbH

Haselwander Str. 5
D-77746 SCHUTTERWALD (DEUTSCHLAND)
Tel. +49 (0) 781-9482590
Fax +49 (0) 781-9482592

HYDRO LEDUC N.A., Inc.

19416 Park Row - Suite 170
HOUSTON, TEXAS 77084 (USA)
Tel. +1 281 679 9654
Fax +1 832 321 3553



Complete catalogues available at:
www.hydroleduc.com



HYDRO LEDUC

SAS with capital of 4 065 000 euros

Siret 319 027 421 00019

RC Nancy B 319 027 421

mail@hydroleduc.com

